

Water softening systems in cabinet

R2D2-72 (Articlenumber 1111.0006)

Single softener in cabinet design for softening drinking and service water up to a maximum of 30 °C.

The R2D2-72 consists of:

GFK pressure tank, filled with high-quality ion exchange resin, modern design, cabinet housing with a maximum salt storage capacity of 50 kg, sliding lid, volume-controlled central control valve, type BNT 1650, integrated fine blending valve, suction device and connecting line to the central control valve, wastewater hose, 12 mm Ø, 2,000 mm long.



R2D2-72



Control valve
BNT 1650

Technical Data	R2D2-72
Performance Data	
For households up to	2-7 persons
Capacity at 10°dH	7.200 l
Capacity at 15°dH	4.800 l
Capacity at 20°dH	3.600 l
Nominal flow rate*	2,10 m ³ /h
Nominal flow rate**	0,7 m ³ /h
Maximum raw water pressure	6,0 bar
Minimum raw water pressure	2,0 bar
Pressure loss at maximum flow	0,6 bar
Salt consumption per regeneration	2,88 kg
Regeneration time	45 minutes
Physical Data Cabinet Housing	
Height Cabinet Housing	1.100 mm
Width Cabinet Housing	220 mm
Depth Cabinet Housing	460 mm
Maximaler Salzvorrat	50 kg
Physical Data GFK Pressure Tank	
GFK pressure tank type	8" x 35"
Resin content	18 l
Control Valve	
Control valve	BNT 1650
Water connections	1" AG
Wastewater connection	12 mm
Electrical Characteristics and Conditions	
Power consumption	3 Watt
Electrical connection	230 / 50 / 24 V
Maximum water temperature	30 °C
Total system weight	32 kg
Articlenumber	1111.0006

* nach DIN 19636 (20 °dH auf 8 °dH)

** von 20°dH auf 0,5 °dH (40 BV / h)

Dimensional drawing for the technical data

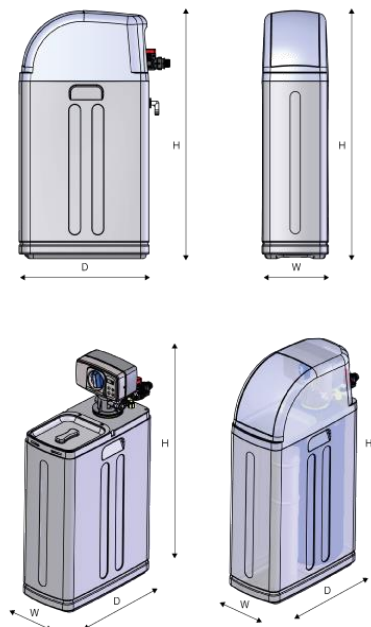

Installation Conditions

- Drinking or raw water connection
- Socket 230 V / 50 Hz
- Waste water connection
- Pressure reducer at > 6 bar
- House water filter at the inlet